



PUMPS

**OPERATION & INSTRUCTION MANUAL
SERIES : PCF**



JAY AMBE ENGINEERING CO.
AN ISO 9001 : 2000 COMPANY



PUMPS

1 INTRODUCTION

1.1 Preface

- This manual contains important and useful information for the proper functioning and maintenance of the pump. It also contains important instructions to prevent possible accidents and serious damage and to ensure the safe and smooth functioning of this pump.
- Read this manual carefully before commissioning the pump. Familiarize yourself with the operation of the pump and strictly obey the instructions!
- The data published here comply with the most recent information at the time of going to press. However they may be subject to later modifications.
- JEC Pumps reserves the right to change the construction and design of the product at any time without being obliged to change earlier deliveries accordingly.

1.2 General

- The manual contains instructions for the safe operation of the pump. Operators and maintenance staff shall be familiarized with these instructions.
- This manual has been compiled by JEC Pumps with the utmost care. JEC Pumps cannot guarantee the completeness of this information and therefore assumes no liability for possible deficiencies in this manual. JEC Pumps reserves the right to change the safety instructions at any time.

1.3 Guarantee

JEC Pumps shall not be bound to any guarantee other than the guarantee accepted by JEC Pumps. In Particular, JEC Pumps will not assume any liability for explicit and/or suitability of the articles supplied. The guarantee shall forthwith and legally defunct in case:

- Installation and/or commissioning have not been carried out as per the instructions.
- Service and/or maintenance have not been carried out strictly in accordance with the instructions.
- Necessary repairs have not been carried out by our personnel or have been carried out without our prior written consent.
- The spare parts used are not original JEC Pumps parts.
- The articles supplied have been changed without our prior written consent.
- The articles supplied are used amateurishly, carelessly, improperly and/or negligently.
- The articles supplied become defective due to out side circumstances beyond our control.

1.4 Service and support

This manual is intended for technicians and maintenance staff and for those who are in charge of ordering spare parts.

Ordering spare parts

This manual contains the spare – and replacement parts recommended by JEC Pumps.

Pump number

The pump number is stated on the pumps type plate. Please refer this number and the other data maintained on the type plate while corresponding or ordering parts.

1.5 Inspection of delivered items

- Check the consignment immediately on arrival for damage and conformity with the advice note.
- In case of damage and/or missing parts, have a report drawn up by the carrier at once.

1.6 Lifting

If a complete pump unit has to be lifted, the slings should be fixed as shown in figure 1.

If only pump has to be lifted, the slings should be fixed as shown in figure 2.



PUMPS

Figure 1 : Lifting instructions - Pump set

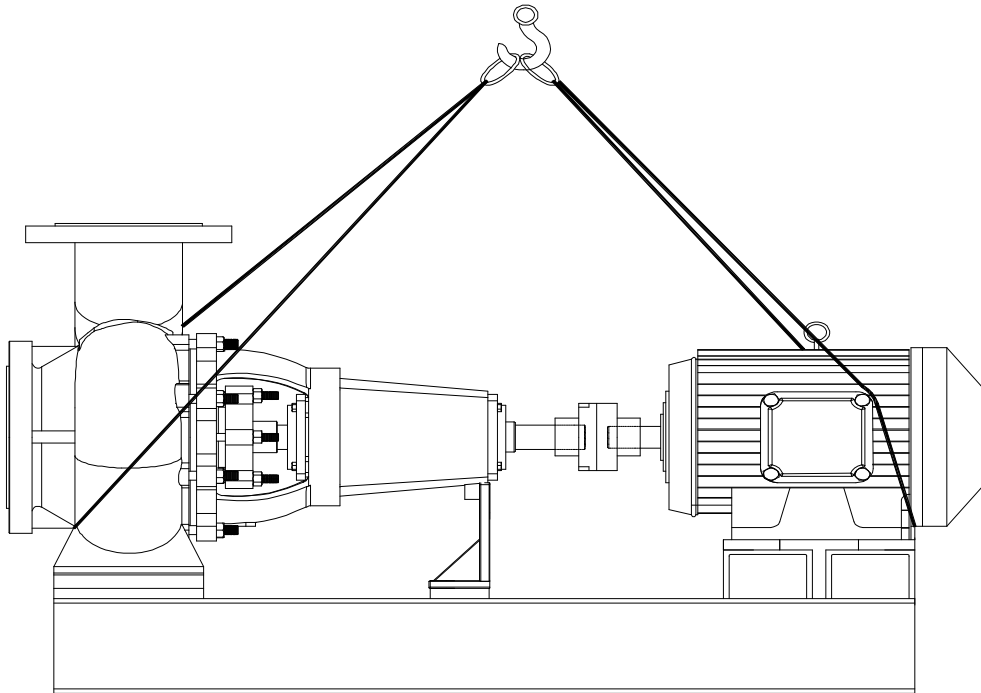
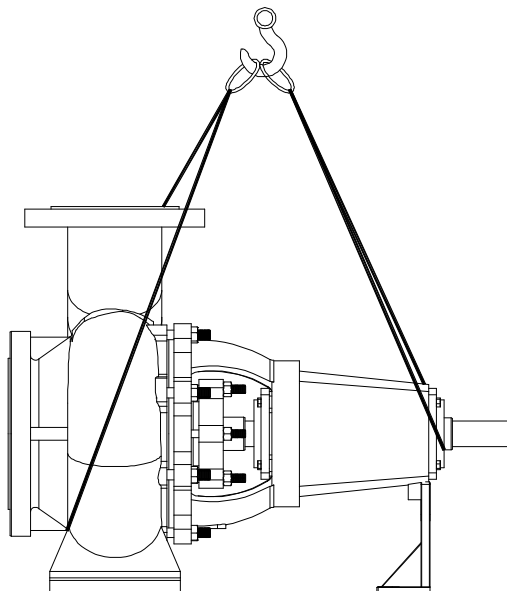

Figure 2 : Lifting instructions – Pump

NOTE: Proper care should be taken to protect pump and/or prime mover and/or paint at contact area of sling or rope at the time of lifting.

1.7 Storage

In case the pump is not immediately being used, the shaft has to be rotated manually twice a week.





PUMPS

2 General

2.1 Pump Description

The PCF is a range of horizontal non-self-priming centrifugal pumps according to ANSI B73.1 Flange dimensions, bolt circle and numbers of holes comply with ISO 2858 / DIN 24256 The pump is driven by a standard IEC foot motor. The power is transmitted through a coupling

Hydraulic Range:

Delivery head up to 100 M

Capacity up to 300 m³/hr

2.2 Application

In general, the PCF pumps can be used for thin, clean or slightly polluted liquids. The liquids should not affect the pump materials. The maximum allowed system pressure and temperature and the maximum speed depend on the pump type and the pump construction.

Please do not use the pump for purchases other than for which it is delivered.

3 Installation

3.1 Safety

- Read this manual carefully prior to installation and commissioning. Non-observance of these instructions can result in serious damage to the pump and this will not be covered under the terms of our guarantee. Follow the instructions step by step.
- Make sure the motor cannot be started when work is done to the pump-motor combination and running parts are insufficiently shielded.
- If danger arises in case of static electricity, the entire pump unit should be earthed properly.
- If there is a danger that the pumped liquid might be harmful to men or the environment, the user should take appropriate measures for safe drainage. Also possible leakage of fluid from the shaft seal should be safely discharged.

3.2 Flushing

Before putting the pump into operation, drain off any preservative agent and flush the pump thoroughly with water.

3.3 Environment

- The foundation must be hard, level and flat.
- The area in which the pump unit is to be placed should be adequately ventilated. A too high ambient temperature and air humidity, as well as a dusty environment may have a negative effect on the functioning of the motor.
- Around the pump unit there should be enough space to operate and if necessary repair the pump.
- Behind the cooling air inlet of the motor there should be a free area of at least ¼ of the electric motor diameter, to ensure unobstructed air supply.

3.4 Mounting

3.4.1 Installation of the set

Pump and motor shafts of complete sets are adjusted perfectly in line in the works. In case of permanent arrangement place the base plate on the foundation with the aid of shims and tighten the nuts on the foundation bolts carefully.

Check the alignment of pump and motor shafts and realign, if necessary according to the instructions in figure 3



PUMPS

3.4.2 Assembly

If the pump and the electric motor still have to be assembled, proceed as follows:

- Mount the two coupling halves on the pump and motor shaft respectively.
- Place the pump on the foundation slab. Secure the pump with bolts.
- Place the electric motor on the foundation slab. Between the two coupling halves there should be a gap of 3 mm.
- Align the coupling to the following instructions.

3.4.3 Alignment of the coupling

- Place a ruler (A) on the coupling. The ruler should touch both coupling halves across the whole width. See figure 3.
- Do the same check against both sides of the coupling near the axis.
- If required, Place shims under the feet of the pump or electric motor.

Figure 3 : Alignment of the coupling

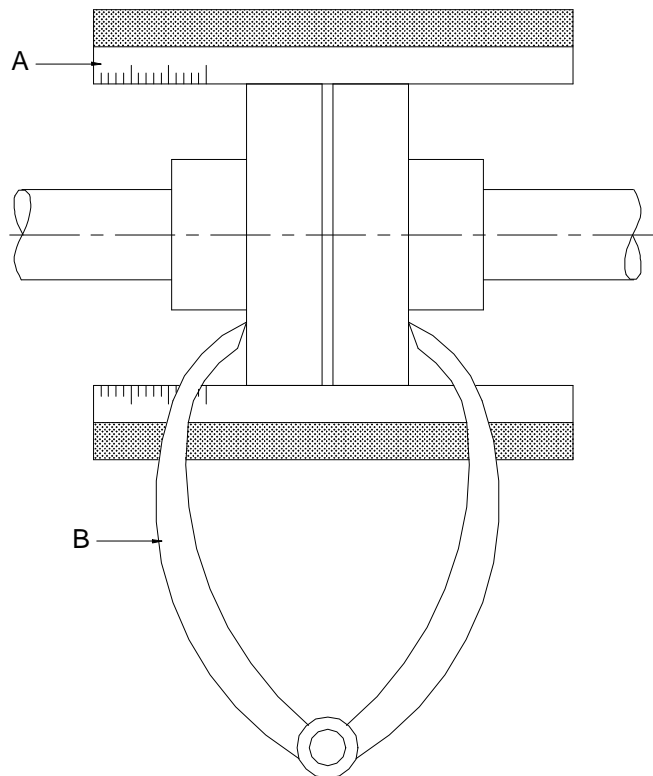

- For all security the alignment is also checked with a pair of outside caliper (B) at 2 diametrically opposite points of the side surfaces of the coupling halves. See figure 3.

3.4.4 Tolerances for aligning coupling

The maximum allowable tolerances in the alignment of the coupling halves are shown in the table below. See figure 4.



PUMPS

Figure 4 : Aligning tolerances

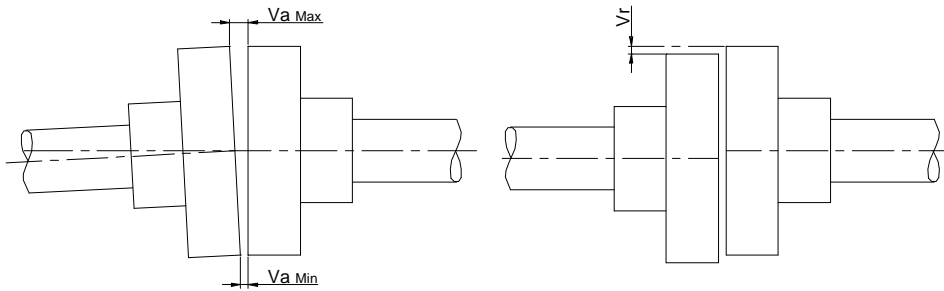

Outer diameter coupling (mm)	Va min (mm)		Va max (mm)		Va max-Va min (mm)	Vr max (mm)
	Non spacer	Spacer	Non spacer	Spacer		
81 - 95	2	5	4	6	0.15	0.15
96 - 110	2	5	4	6	0.18	0.18
111 - 130	2	5	4	6	0.21	0.21
131 - 140	2	5	4	6	0.24	0.24
141 - 160	2	6	6	7	0.27	0.27
161 - 180	2	6	6	7	0.30	0.30
181 - 200	2	6	6	7	0.34	0.34
201 - 225	2	6	6	7	0.38	0.38

3.5 Piping

- The piping of the suction and delivery connections must fit exactly and must not be subject to stress during operation.
- The passage of the suction pipe must be amply dimensioned. This pipe should be as short as possible and run towards the pumps in such a way that no air pockets can arise. If this is not possible, a venting facility should be provided at the highest point of the pump an eccentric reducer should be applied to prevent air pockets and whirls. See figure 5

Figure 5 : Eccentric reducer



PUMPS

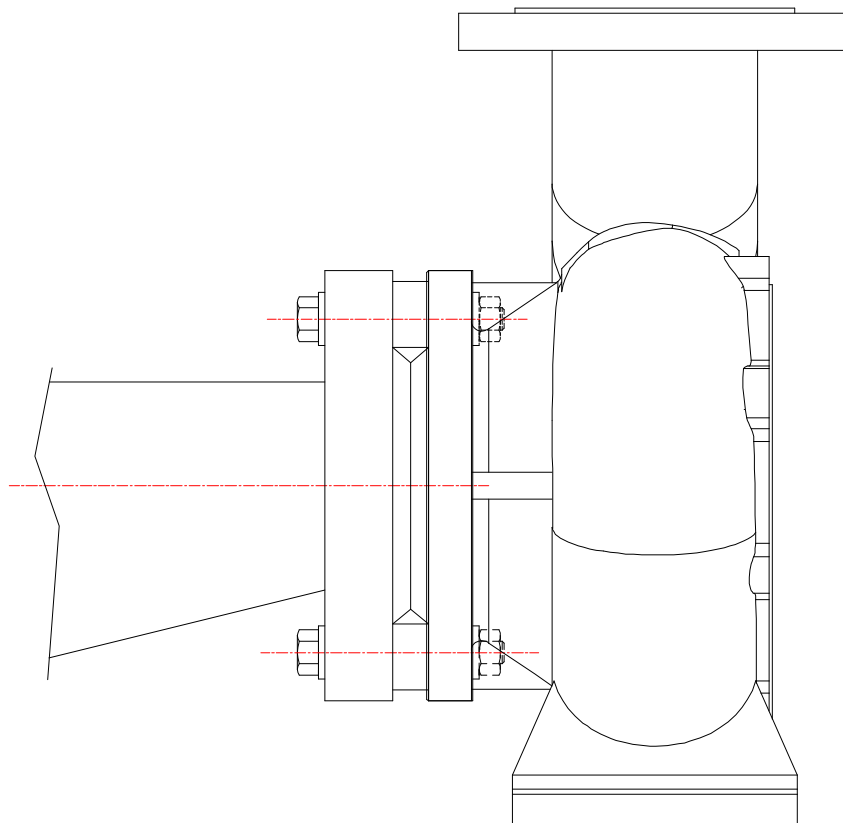

- If there is a risk that the system pressure might be exceeded, for instance because of an excessive inlet pressure, appropriate measures should be taken by mounting a safety valve in the piping.
- Sudden changes in the rate of flow can lead to high pressure impulses in the pump and the piping (water shock). Therefore don't use quick-acting closing devices, valves etc.

3.6 Mounting accessories

- Mount any parts that may have been supplied separately.
- If the liquid does not flow towards the pump, mount a foot valve at the bottom of the suction pipe. If necessary, combine this foot valve with a suction strainer to prevent impurities from being drawn in.
- When mounting, place temporarily (for first 24 operating hours) fine gauze between suction flange and suction pipe so as to prevent internal pump parts from being damaged by foreign matter. If the risk of damage continues to exist, mount a permanent filter.
- In case of a pump with a cooled stuffing box, connect the cooling chamber to the cooling system.

4 Commissioning

4.1 Control pump

- Construction with stuffing box: check whether the gland nuts have not been over tightened. If necessary, loosen the gland nuts and retighten them by hand.
- Check whether the shaft turns freely. Do this by turning the shaft end at the coupling a few times by hand.



PUMPS

4.2 Control Motor

If driven by an electric motor:

- Check whether the fuses have been mounted.

If driven by an engine:

- Check whether room in which the engine is placed is well ventilated.
- Check whether the exhaust of the engine is not obstructed.
- Before starting the engine check the oil level.
- Never turn the engine in a closed room.

4.3 Checking the sense of rotation

- The sense of rotation of the pump is indicated by arrow. Check whether the sense of rotation of the motor corresponds with that of the pump.
- Let the motor run for only a short time and check the sense of rotation.
- If the sense of rotation is not correct, change connecting wire of motor so as to match with the rotation of pump.
- Mount the coupling guard.

4.4 Lubrication of bearings

The bearing of pumps provided with grease-lubricated are filled with grease at the time of delivery.

Pump provided with oil-bath lubricated bearing are supplied without oil. See chapter 7 for the specifications of the oil to be used.

- Fill the sump through the oil filling orifice up to the middle of the oil level indicator.
- After that, fill the constant oil leveler entirely.

4.5 Preparing the unit for commissioning

Proceed as follows, both when the unit is put into operation for the first time and after the pump has been overhauled.

- Fully open the stop valve in the suction pipe. Close the delivery stop valve.
- Fill the pump and the suction pipe with the liquid to be pumped.
- Turn the pump shaft few times by hand and fill up more liquid, if necessary.

4.6 Starting the pump

- Open the stop valve in the supply piping for flushing or cooling liquid, if the pump is supplied with a flushing or cooling system.
- Start the pump.
- As soon as the pump is under pressure, slowly open the delivery stop valve until the working pressure is attained.

4.7 Adjustment of shaft sealing

4.7.1 Stuffing-box packing

After the pump is started, the stuffing box will show a certain amount of leakage. Because of the expansion of the packing fibers, this leakage will gradually decrease. Make sure that the packing never runs dry. To prevent this, loosen the gland nuts to the extent that the stuffing box leaks drop-wise. As soon as the pump has reached the proper temperature (and leakage is still too much) the gland can be adjusted permanently.

- Tighten both gland nuts, one after the other, a quarter turn.



PUMPS

- Wait 15 minutes after each adjustment before making the next adjustment.
- Continue in this way until an acceptable drop-wise leakage has been attained. (20-30 drop/minutes)

4.7.2 Mechanical seal

A mechanical seal may never show visible leakage.

4.8 Control

If a pump is in operation pay attention to the following:

- The pump should never run dry.
- Never use a stop valve in the suction pipe to control pump capacity. The stop valve should always be fully opened during operation.
- Check whether the absolute inlet pressure is sufficient, so that no vapour can be formed.
- Check whether the pressure difference between suction and delivery pressure corresponds with the specification for the duty point of the pump.



PUMPS

5 Maintenance

5.1 Daily maintenance

Regularly check the outlet pressure.

5.2 Shaft sealing

5.2.1 Gland packing

- Do not tighten the gland nuts any more after the running-in period and adjustment.
- If in time the gland packing starts to leak excessively, new gasket rings have to be fitted rather than tightening the gland nuts further.

5.2.2 Mechanical seal

A mechanical seal generally requires no maintenance; however, it should never be allowed to run dry. If there are no problems it is no advisable to dismantle the seal. As the facing surfaces are running in one another, dismantling always means replacement of the mechanical seal. When the mechanical seal is leaking it has to be replaced.

5.3 Lubrication of the bearings

5.3.1 Grease-lubricated bearings

Bearing brackets with two grease-packed deep-groove ball-bearings require no maintenance. The version with a cylindrical bearings and a double-row angular contact ball-bearing requires re-greasing after 1000 hours of operation. The bearings are filled with grease during assembly. In case the pump is overhauled, the bearing housing and the bearings have to be cleaned and provided with new grease. See chapter 7 for recommended greases.

5.3.2 Oil-bath lubricated bearings

During operation the oil chamber of the bearing housing should never be empty, so take care to top up timely. The oil should be changed once a year. If the oil temperature is higher than 80°C, the oil should be changed more often. For recommended oils see chapter7.

5.4 Environmental influences

- Regularly clean the filter in the suction pipe or the suction strainer at the bottom of the suction pipe, as the inlet pressure may become too low if the filter of the suction strainer is fouled.
- If there a risk that the pumped liquid expands during solidification or freezing, the pump has to be drained and, if necessary, flushed after is has put of service.
- If the pump is out of service for a long time, it has to be preserved.

5.5 Faults

- Switch off the current supply to the pump unit. Block the working switch with a lock or remove the fuse. In case of a combustion engine: switch off the engine and close the fuel supply to the engine.
- Close the stop valves.
- Determine the nature of the fault.
- Try to determinate the case of the fault (see chapter 6) and take the appropriate measures.

OR

Contact your installer!



PUMPS

6 Cause of failures

If general, failures in a pump unit are attributable to the following causes:

- Failures in the pump
- Failures or faults in the piping system
- Faults due to wrong installation or commissioning.
- Faults due to a wrong pump selection.

Most frequently occurring failures	Possible causes
Pump doesn't delivers any liquid	1 2 3 4 5 6 7 8 9 10 11 13 14 17 19 20 21 29
The volume flow of the pump is insufficient	1 2 3 4 5 6 7 8 9 10 11 13 14 15 17 19 20 21 28 29
The discharge head of the pump is insufficient	2 4 5 13 14 17 19 28 29
Pump stalls after it has been in to operation	1 2 3 4 5 6 7 8 9 10 11
The power consumption of the pump is higher than normal	12 15 16 17 18 22 23 24 25 26 27 32 34 38 39
The stuffing box is leaking excessively	6 7 23 25 26 30 31 32 33 43
Shaft packing or mechanical seal have to be replaced to often	6 7 23 25 26 30 32 33 34 35 36 41
Pump vibrates or makes noise	1 9 10 11 15 18 19 20 22 23 24 25 26 27 29 37 38 39 40
Bearings wear too soon or get hot	23 24 25 26 27 37 38 39 40 42
Pump runs with difficulty, gets hot or stuck	23 24 25 26 27 34 37 38 39 40 42

Possible causes:

- 1 Pump or suction pipe not sufficiently filled or de-aerated
- 2 Gas or air coming from the liquid
- 3 Air lock in the suction pipe
- 4 Suction pipe leaks air
- 5 The pump sucks in air through the stuffing box
- 6 The sealing or flush water pipe to the stuffing box is not connected or blocked.
- 7 The lantern ring in the stuffing box has been mounted wrongly.
- 8 The mano-metric suction head is too high.
- 9 Suction pipe or suction strainer is blocked.
- 10 Insufficient immersion of foot valve or suction pipe during operation of the pump.
- 11 NPSH available too low.
- 12 Speed to high.
- 13 Speed too low.
- 14 Wrong sense of rotation.
- 15 Pump doesn't work at the right duty point.
- 16 Liquid density differs from the calculated liquid density.
- 17 Liquid viscosity differs from the calculated viscosity.
- 18 Pump works when the liquid flow is too low.



PUMPS

- 19 Wrong pump selection.
- 20 Obstruction in impeller or pump housing.
- 21 Obstruction in the piping.
- 22 Wrong installation of the pump unit.
- 23 Pump and motor not well aligned.
- 24 Rotating part running out of true.
- 25 Imbalance in rotating parts (for instance impeller, coupling).
- 26 Pump shaft is running out of true.
- 27 Bearing faulty or worn out.
- 28 Seals rings faulty or worn out.
- 29 Damaged Impeller.
- 30 Pump shaft or shaft sleeve at shaft packing or running surfaces of the mechanical seal are worn out or damaged.
- 31 Worn or dried up shaft packing.
- 32 Not well packed stuffing box or bad mounting of the mechanical seal.
- 33 Packing type of the mechanical seal not suitable for the operation liquid or operation circumstances.
- 34 Gland of seal cover has been tightened too much or crookedly.
- 35 No water cooling of stuffing box at high temperatures.
- 36 The sealing or flushing liquid to the stuffing box or the mechanical seal is polluted.
- 37 Axial retaining of impeller or pump shaft is defective.
- 38 The bearings have been mounted wrongly.
- 39 Too much or too little bearing lubrication.
- 40 Wrong or polluted lubricant.
- 41 Impurities in the liquid get into the stuffing box.
- 42 Too high axial force because worn dorsal blades or excessive inlet pressure.
- 43 Excessive pressure in packing space due to much play in the smothering bush, blocked by-pass pipe or worn dorsal blades.



PUMPS

7 Technical data

7.1.1 Oil

Recommended oils according to ISO VG 68 classification for ambient temperatures above 15° C

BP	- HLP 68
Chevron	- EP Industrial Oil 68
Esso	- Teresso 68
Shell	- Tellus 68
Mobil	- Mobil D.T.E. Oil Heavy Medium

7.1.2 Oil contents

Contents (mini. quantity) 400 ml

7.1.3 Grease

Recommended greases according to NLGI-2 classification;

BP	- Energrease LS 2
Shell	- Alvania R2
Mobil	- Mobilux EP 2
Chevron	- Polyurea EP grease 2
Esso	- Beacon 2
SKF	- Alfalub LGMT 3



PUMPS

Exploded view for Soft Packed Pump

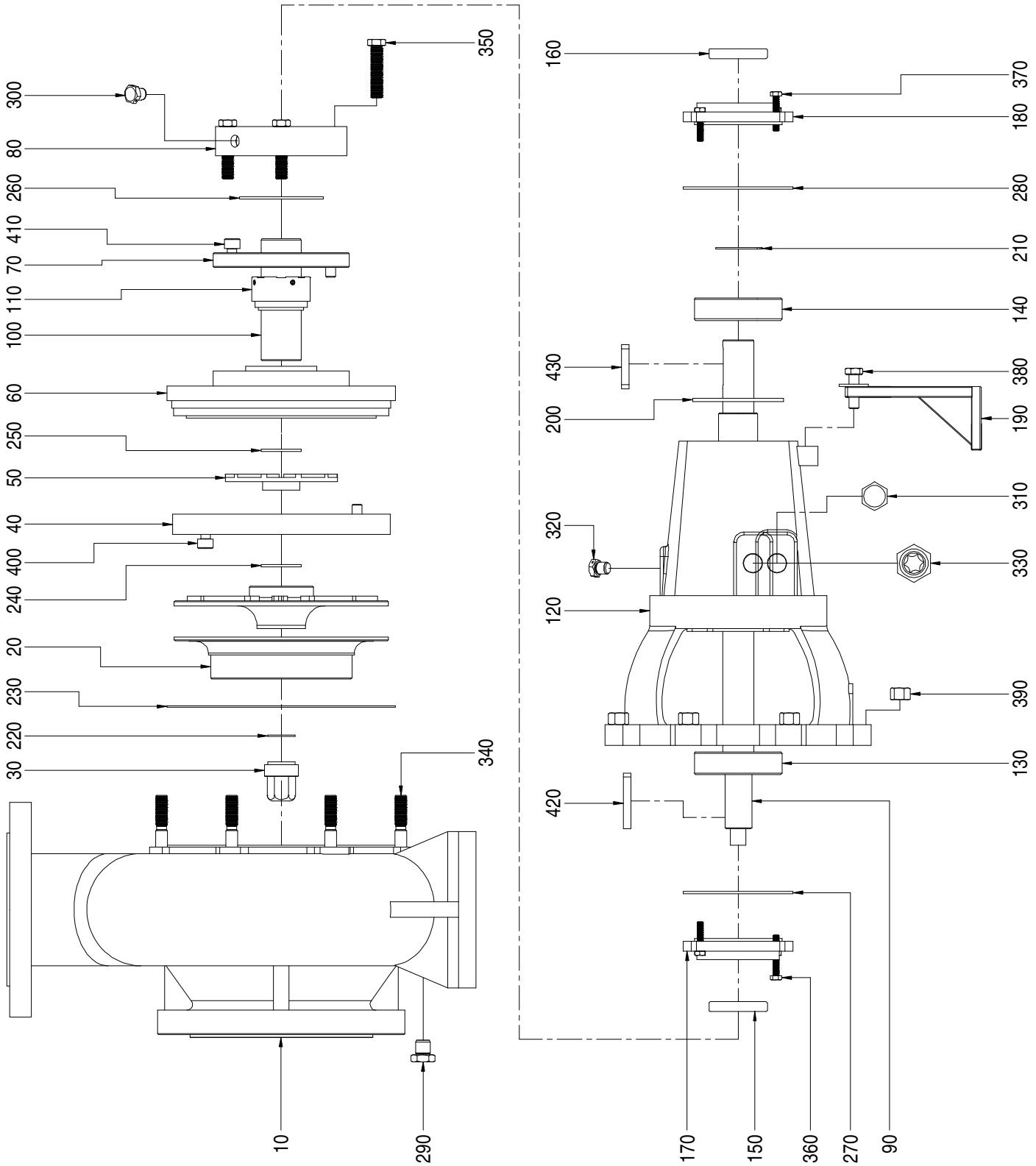



PUMPS

Bill of Material for Expeller Type Mechanical seal fitted pump

Pos. No.	Qty.	Description	Material						
			CI	CS	CF8	CF8M	A 20	HC	HB
10	1	Volute casing	CI	CS	CF8	CF8M	A 20	HC	HB
20 *	1	Impeller	CI	CS	CF8	CF8M	A 20	HC	HB
30	1	Impeller lock nut	SS 410		CF8	CF8M	A 20	HC	HB
40	1	Stuffing Box	CI	CS	CF8	CF8M	A 20	HC	HB
50	1	Expeller	CI	CS	CF8	CF8M	A 20	HC	HB
60	1	Cover Plate	CI	CS	CF8	CF8M	A 20	HC	HB
70	1	Seal Plate	CS		CF8	CF8M	A 20	HC	HB
80	1	Gland Plate	CS		CF8	CF8M	A 20	HC	HB
90	1	Shaft	SS 410		SS 304	SS 316			
100 *	1	Shaft sleeve	SS410		SS 304	SS 316	A 20	HC	HB
110 *	1	Mechanical seal	As per Requirement						
120	1	Bearing housing	CI						
130 *	1	Ball bearing (NDE)	Steel						
140 *	1	Ball bearing (DE)	Steel						
150 *	1	Oil seal (NDE)	NBR						
160 *	1	Oil seal (DE)	NBR						
170	1	Bearing cover (NDE)	CI						
180	1	Bearing cover (DE)	CI						
190	1	Support Foot	CI						
200 *	1	Internal circlip (BH)	Steel						
210 *	1	External circlip (SH)	Steel						
220 *	1	Gasket for impeller lock pin	PTFE						
230 *	1	Gasket for volute casing	PTFE						
240 *	1	Gasket between impeller and expeller	PTFE						
250 *	1	Gasket between expeller and sleeve	PTFE						
260 *	1	Gasket between seal plate and gland plate	PTFE						
270 *	1	Gasket for bearing cover (NDE)	Oil paper						
280 *	1	Gasket for bearing cover (DE)	Oil paper						
290	1	Drain plug for volute casing	Steel		SS 304	SS 316	A 20	HC	HB
300	1	Plug for gland quench	Steel		SS 304	SS 316			
310	1	Oil drain plug	Steel						
320	1	Breather plug for oil filling	Aluminium						
330	1	Oil level indicator	Aluminium						
340	6	Stud for volute casing	Steel		SS 304				
350	4	Bolt for gland plate	Steel		SS 304				
360	4	Bolt for bearing cover (NDE)	Steel						
370	4	Bolt for bearing cover (DE)	Steel						
380	1	Bolt for support foot	Steel						
390	6	Hex nut for volute casing	Steel		SS 304				
400	4	Stuffing box lock allen cap	Steel		SS 304	SS 316	A 20	HC	HB
410	4	Seal plate lock allen cap	Steel		SS 304				
420 *	1	Drive pin for Impeller	SS 316						
430 *	1	Drive pin for coupling	Steel						

* Recommended spares